

**\*  
NOTA ESPECIAL**  
PARA ASEGURAR LA POSICION CORRECTA DEL CORCHO ES DESEABLE CONTROLAR LA APERTURA DEBAJO DE ESTE PUNTO DE MANERA QUE SEA IGUAL O MAYOR QUE EL PUNTO MAS ESTRECHO ARRIBA.

**SPECIAL NOTE**  
TO ENSURE A CORRECT POSITION OF THE CORK IT IS DESIRABLE TO CONTROL THE OPENING BELOW THIS POINT TO BE EQUAL OR SLIGHTLY GREATER THAN THE SMALLEST OPENING ABOVE.

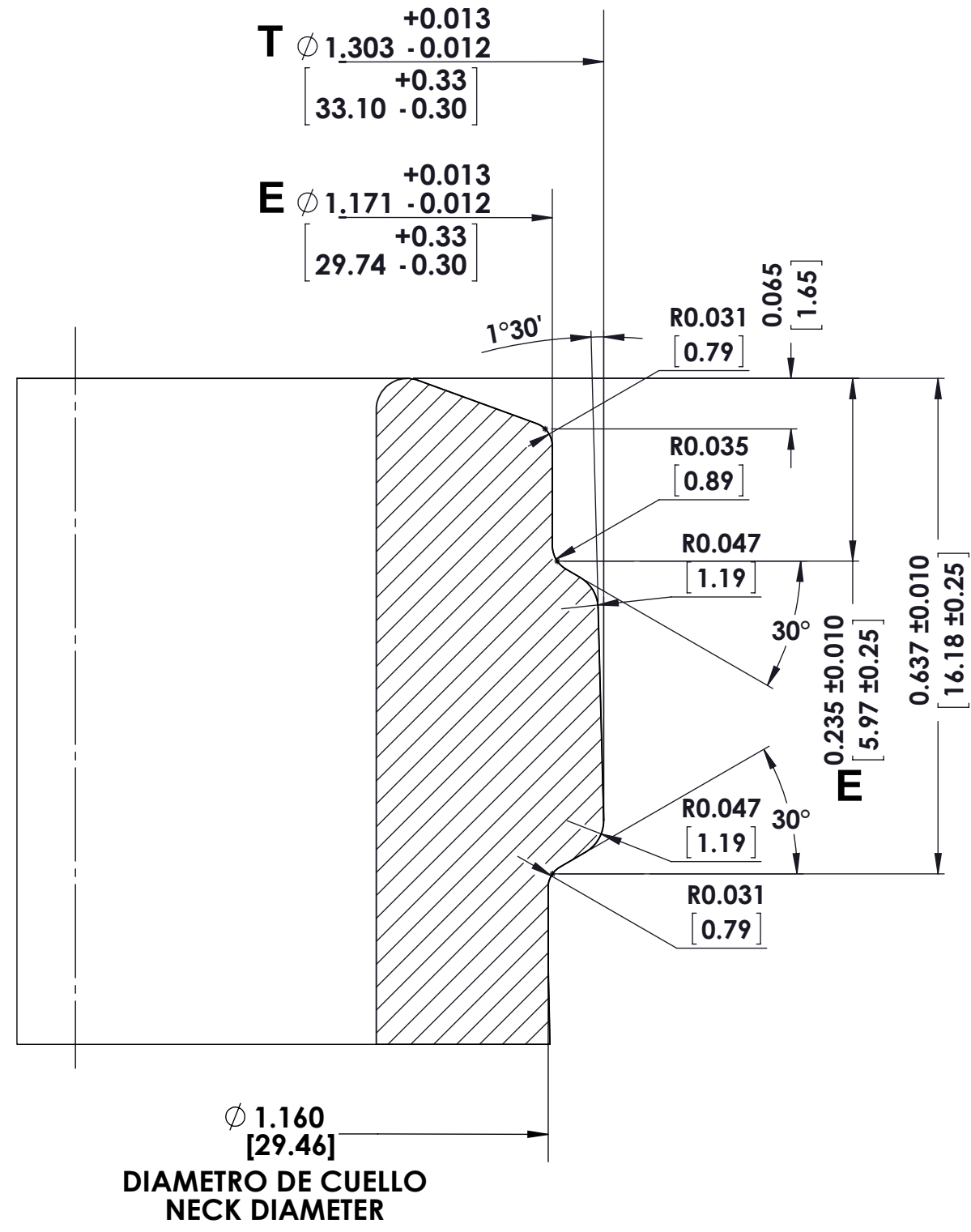

**LEYENDA 750 ML DEBE APARECER EN UNA MITAD DE LA BOTELLA, LETRA SECC. MEDIA CAÑA REALZADA 0.012" MAX. EN VIDRIO.**

**CAPACITY LETTERING "750 ML" MUST APPEAR ON ONE SIDE OF BOTTLE ROUND, NOSED STYLE RAISED 0.012" MAX. IN GLASS.**

**PUNTOS DE IDENTIFICACION DE CAVIDAD  
AUTOMATIC CAVITY IDENTIFICATION  
CODE AREA**

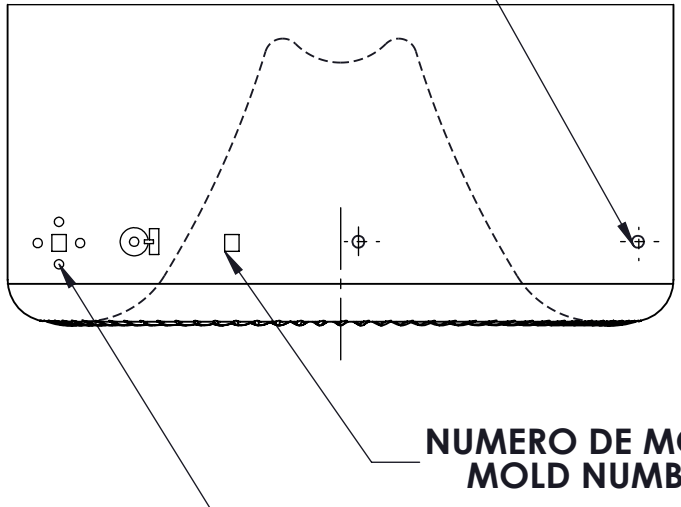
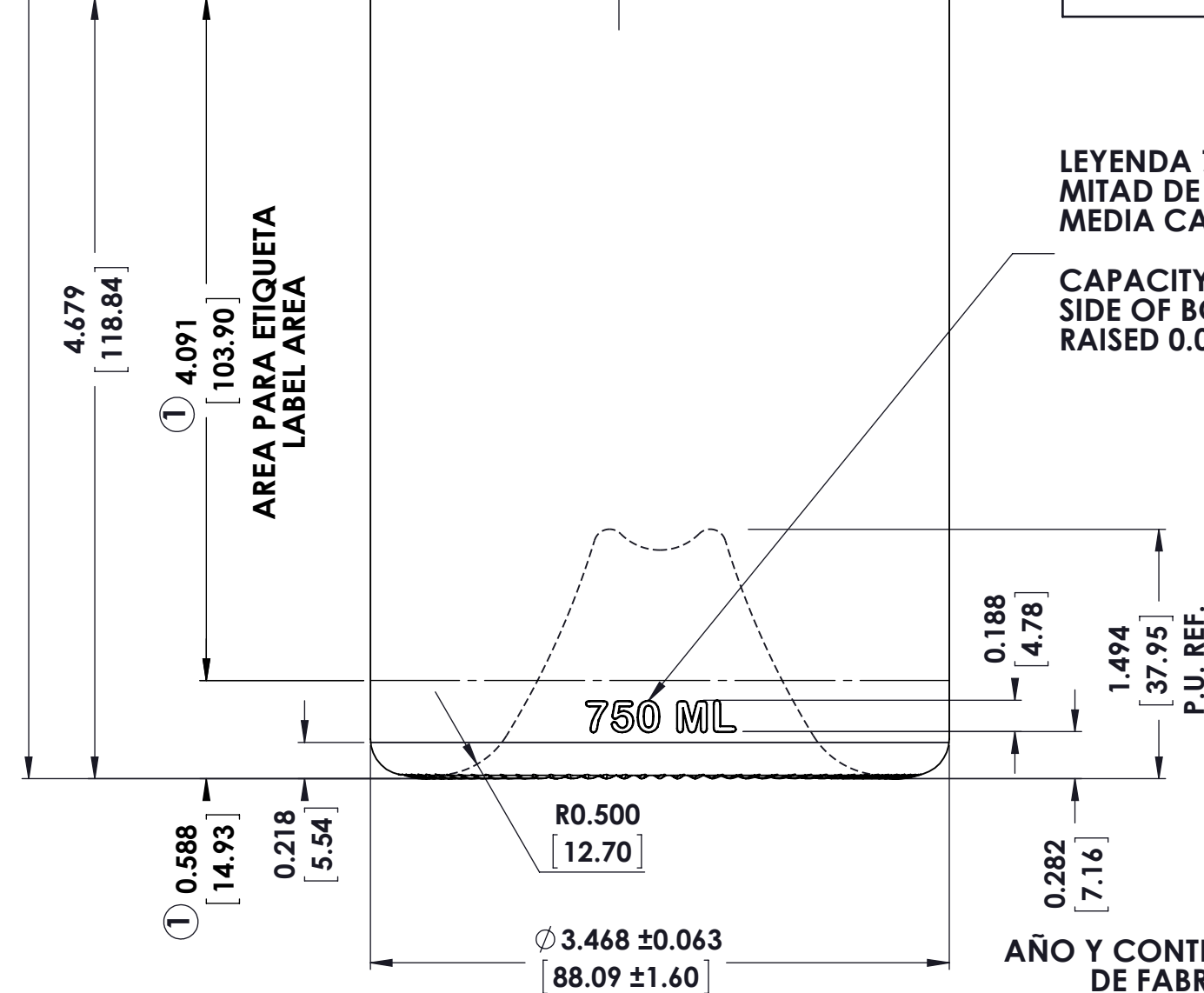

**VISTA FRONTAL  
FRONT VIEW**

**VISTA POSTERIOR  
BACK VIEW**

